

VSM 422

VESSEL SYSTEMS MONITOR



4 METERS IN 1

- 1. DC Systems Monitor**
voltage (up to 3 batteries), amperage, battery state of charge—amp hours remaining, time remaining, % charge, battery temperature, cycle count
- 2. AC Systems Monitor**
voltage, amperage, watts, frequency
- 3. Tank Monitor** (up to 3 tanks)
gasoline, diesel, water, waste
- 4. Bilge Monitor**
bilge pump—active, cycle count, duration/hr, cycle/24 hr

- Alarms—high and low**
DC—alarms for all values
AC—alarms for voltage, amperage, and frequency
Tank—high and low level alarms for fuel, water and waste
Bilge—alarms for cycles, duration/hr
- Display—three intuitive modes**
multi-line text to monitor all systems at a glance, icons for simple visual status, or large font that can be read from a distance
- Mounting—versatile case design** offers three mounting options
- Customization—programmable legends and adjustable alarm functions** can be customized

BLUE SEA SYSTEMS ULTRASONIC TANK SENDERS AVAILABLE

1810 used for diesel, water or waste (32" tank depth)



1811 used for gasoline (24" tank depth)



PN 1800
Actual size

Replace these 4 meters with the VSM 422



Part Number

1800 | Vessel Systems Monitor

3 Intuitive Display Modes

Large Font

Icon

Multi-line Text

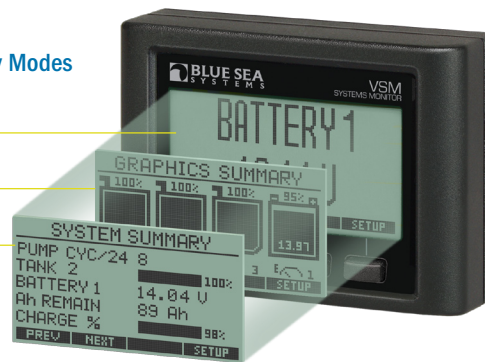



DC Specifications

Nominal System Voltage	12 or 24 Volts
Operating Voltage	8.5-33.0 Volts
Minimum Current Draw	35mA@12 Volts, backlight off 18.8mA@24 Volts, backlight off
Voltage Accuracy	+/- 0.5%
Current Range	0-500 Amperes
Current Accuracy	+/- 1.0%

AC Specifications

Nominal System Voltage	120 Volts@60 Hz, North America 230 Volts@50 Hz, Typical of Europe
Operating Voltage	0-300 Volts
Voltage Accuracy (RMS)	+/- 0.5%
Current Range	0-150 Amperes
Current Accuracy (RMS)	+/- 2.0%
Frequency	40-90 Hz

Regulatory

CE Marked for E60945 electro-magnetic interference

IP67-VSM 422 Surface Mount Gasket creates a waterproof seal on unit face-temporary immersion for 30 minutes.

VESSEL SYSTEMS MONITOR

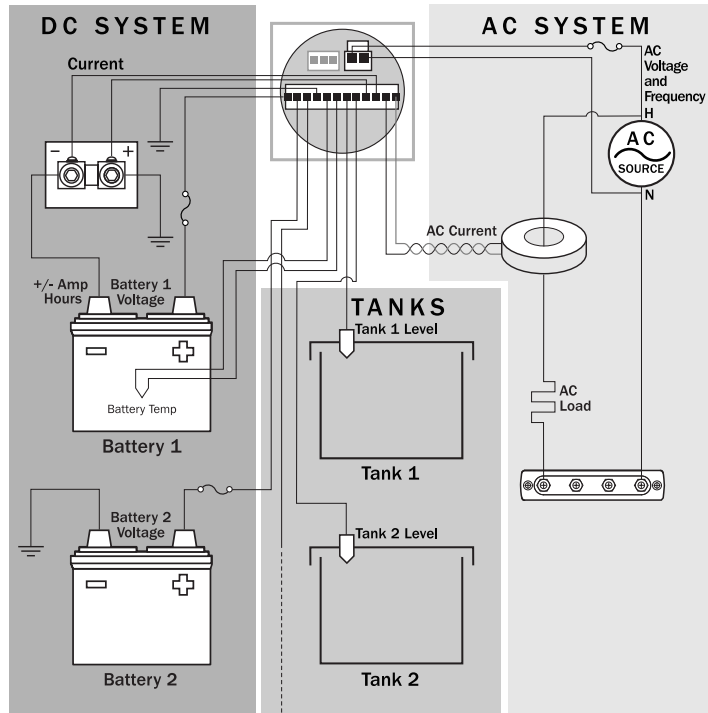

Select one optional input

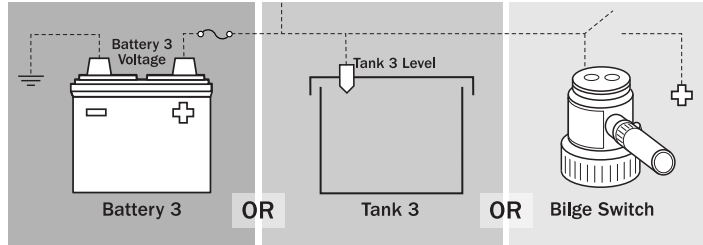

Three Mounting Options

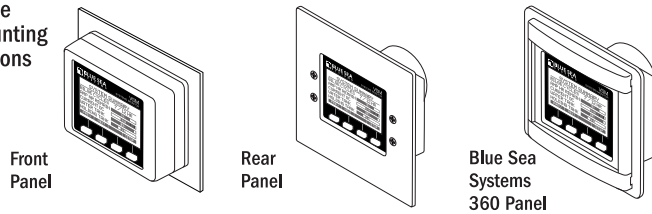

Included in Retail Packaging: head unit, surface mount bezel, surface mount gasket, DC Current Shunt - PN 8255, AC Current Transformer - PN 8256, Battery Temperature Sensor - PN 1820, connectors and mounting screws

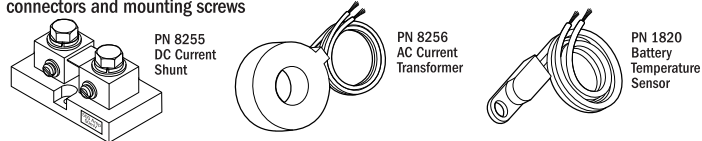

Tank Senders Supported:

10 - 180 Ω VDO—Typical of Europe

240 - 33 Ω Teleflex—North America

Blue Sea Systems Ultrasonic Tank Senders (sold separately)

• for diesel, water, or waste - PN 1810 (32" tank depth)

• for gasoline - PN 1811 (24" tank depth)

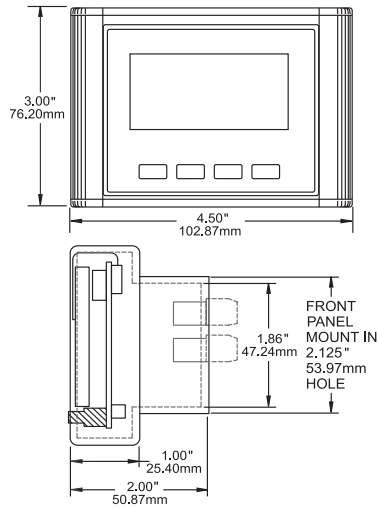

425 Sequoia Drive Bellingham, WA 98226 USA

800-222-7617 (USA and Canada)

Phone: 360-738-8230 Fax: 360-734-4195

www.bluesea.com

Specifications subject to change.

See www.bluesea.com for additional information and specifications.

6847 Rev.002