

AC Digital Meters

Single-Function Meters



8237 AC Digital Voltmeter
8238 AC Digital Ammeter
8239 AC Digital Frequency

Multi-Function Meters



8247 AC Digital Multimeter with Alarm

Shock Hazard During Installation! Read Manual!

Safety!



WARNING

Electrical shock and fire hazard.
Failure to follow these instructions
May result in injury or death.

To minimize shock and fire hazards:

- 1) Enlist the services of a qualified electrician if you are not experienced and comfortable installing AC devices. Be sure they read this warning page as well.
- 2) Turn off all AC sources before terminating either end of wires #1 & #3, which supply AC power to the meter. This includes generators, inverters, and utility power. For marine and RV installations be sure to unplug shore or park power and disconnect the inverters DC power supply.
- 3) **Special Warning!**
Turn off all AC sources before installing the Current Transformer (CT). **Do not energize until the CT is terminated at the meter. OPEN CT LEADS CAN GENERATE LETHAL VOLTAGES! NEVER OPEN THE CT LEADS DURING OPERATION.** If the meter must be removed short the CT leads.

Specifications

General:	
Display Character Size	9/16"
Input Voltage	80-249V AC*
Maximum Power Consumption	0.027W**
Minimum Power Consumption (Sleep mode PN 8247 only)	0.010W**
Voltage Measurement:	
Range	80-249V AC*
Resolution	0.1V AC
Accuracy (% of Reading)	
90-249V AC (RMS)	± 1.0%***
70-90V AC (RMS)	± 5.0%***
Current Measurement:	
Current Transformer	150A-50mA
Range 1 (Resolution 0.01A)	0.00-9.99A AC(RMS)
Range 2 (Resolution 0.1A)	10.0-150.0A AC(RMS)
Accuracy (% of Reading)	± 1.0%***
Frequency Measurement:	
Range	40-90Hz
Resolution	0.1Hz
Accuracy (% of Reading)	± 0.1%***
Calibrated with sine wave input	
Power Measurement:	
Range 1 (Resolution 10W)	0-9990W
Range 2 (Resolution 0.1kW)	10-45kW
Accuracy (% of Reading)	±5%***
Physical:	
Splashproof front	
Dimensions	Height 2.431" (61.75mm)
	Width 2.896" (73.56mm)
	Depth 3.400" (86.36mm)

* For 120 & 240 Volt AC single phase systems

** Variable with voltage, display intensity, segments illuminated, and sleep mode.

*** ± 1 least digit of resolution

Theory of Operation

The 8200 Series meters incorporate microprocessor control and advanced electronics specifically designed for power monitoring to provide accurate metering with a variety of adjustable user features. AC meters have an internal transformer that supplies both power and voltage sensing. This approach simplifies installation.

Models that have the ability to measure AC current are supplied with a current transformer (CT). The CT is a toroidal transformer (doughnut shaped). The AC line to be measured is passed through the center of the CT. The CT has a full current rating of 150 Amps and when 150 Amps flows in the primary it generates a secondary current of 50mA (0.050A). This current is then processed inside the meter and scaled to read amps. For example, if the AC line was conducting 30A the secondary of the CT

would generate 10mA but it would be displayed as 30.0A. Similarly 1A generates 0.33mA, and 0.1 Amp generates only 0.033mA. This is a very small signal and you must be sure that all connections are secure and well made. It is also necessary to use twisted pair wire to minimize susceptibility to electrical system noise.

Use

A full discussion of AC monitoring and use is beyond the scope of these instructions. The topics mentioned below may be used as a guide but should not be considered comprehensive.

AC systems can benefit from the measurement of four key parameters: Voltage, Amperage, Frequency, and Power. Each tell something about the performance of the system and are more or less required depending on the application.

Voltage, for example, is very important to monitor when using a generator. Excessive voltage can cause equipment damage, and wide voltage swings may indicate voltage regulation, or even fuel supply problems.

Current or amperage monitoring can help avoid overloads when using limited shore power or RV park power.

Frequency should be monitored when generators are a part of the system. Frequency regulation can affect devices such as clocks, light dimmers, and the efficiency of devices with transformers. Typically frequency should not vary more than ± 2 or 3 cycles over the operating range of the generator.

Power displayed is the apparent power, $V_{rms} \times I_{rms}$, and can be used to avoid overloading sources such as an inverter.

Installation Overview

- 1) Physical: The meter must be located in an environment that is safe for high voltage electrical connections. Personnel must not be able to touch the terminals on the back of the meter. The meter should be located in a visible position with easy access for operation of the pushbuttons. The display has adjustable brightness, but for best visibility do not place the meter in full daylight. The location should be dry and protected. The face is splash proof and its circuit boards are coated for corrosion resistance, but it is not intended for use in wet environments or for installation outside without additional protection. All wiring should be in safe and dry raceways with appropriate strain relief.
- 2) Safety: Installation requires high voltage connections in an electrical panel environment. These connections must be made carefully and fused as indicated in the wiring diagram. Be sure all AC sources are off, including inverters and generators. To be sure, disconnect the battery from the inverter and unplug and remove any shore or park power cords. The scope of this document does not include instruction in basic electrical skills necessary to install the meter. If you do not have the necessary basic skills you should employ a qualified electrician.

Power and Voltage Sensing

All models require the same connections to power the meter. Meters with the voltage function use these same connections for voltage sensing. The terminals on the back of the unit are UL rated for 300 Volts. Ungrounded line voltage conductors which feed the meter should be protected by fuses with the appropriate voltage rating for the application. If inline fuses are used be sure there are no exposed parts at line voltage when the fuses are removed. A fast acting fuse with a rating of 0.25 to 0.5A helps protect the meter against transients and the wiring against shorts.

The wiring from the AC source should be short and connected as close to the input to the distribution system as is practical. This means directly down circuit from the main AC distribution circuit breaker.

Current Sensing

Models that have the ability to measure AC current are supplied with a Current Transformer (CT) that is used to sense the current in the AC circuit to be monitored.

To install the CT, identify the current carrying conductor that supplies the circuit of interest, be sure it is de-energized, and disconnect it from where it is terminated, for example, at a circuit breaker. Slide the wire through the center of the doughnut shaped CT and re-connect. Only pass one conductor through the CT. In 120 Volt systems you may pass either the hot or neutral conductor through the CT. In 240 Volt systems you must pass one, or the other, of the hot conductors through the CT. Try to pick the line with the most load. Do not use the neutral conductor to monitor current in a 240V three or four wire system, since in a balanced system the neutral current should be zero.

NOTE:

The two wires from the CT do not have polarity indicated. The polarity does not make a difference for current measurement but for Power measurement it does. **IF THE POWER NUMBER IS ZERO REVERSE THE CT SENSE LEADS.**

Using Multiple Current Transformers

The 8200 Series meters can be used to measure the current flow in both legs of a 240 Volt single phase, three or four wire system, but a switch must be used that is specifically designed for the purpose.

If primary current is flowing and the CT is allowed to become open circuited high voltages are generated that can be lethal to humans and if connected to the meter may cause non-warranty damage. This restriction means that a special switch must be used that shorts the secondary of the CT, except when it is connected to the meter. As the selector switch is turned the terminals of the CT are shorted together, connected to the meter, and then the short is removed.

These types of switches are manufactured by ElectroSwitch (Series 31), Allen Bradley, and Kraus & Naimer, and are available from commercial electrical distributors. The PN 8410 switch and panel is available from Blue Sea Systems for 120/240V applications.

All Models: Startup Sequence



Upon power up the meter goes through a self test sequence which lights all the function LEDs.

All Models: Using * Button for Dimming



Pressing the * button causes the display to dim. There are three levels of brightness. Models with a single button also have a fourth sleep mode in which the display is off with the exception of a single decimal point. Models with three buttons have an automatic sleep mode, which is accessed through the menu as described in the manual.

Three Button Models

The ◀ arrow ▶ buttons have two functions. Normally they change the display between Volts, Amps, Hertz (frequency), and Watts (power). When in the MENU mode they are used to navigate through the functions or adjust the values.

The center * button has three functions. Normally it is used to dim the display. Holding the button for 2 seconds will access the MENU and while in the MENU mode, pressing it is used to SET or store the displayed value to memory.

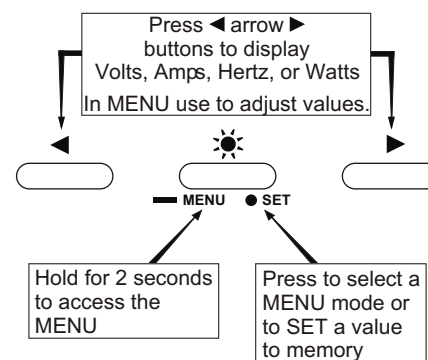

Sleep Mode - SLP



The Sleep mode is a simple power-saving feature. If there are no button presses for 10 minutes the display goes to sleep and only a single decimal point is lit. Pressing any button causes the meter to exit the sleep mode and revert to the last displayed function.

To access the Sleep mode, hold the * button for two seconds. Use the ◀ arrow ▶ buttons to scroll until SLP is in the display. Press * to select the Sleep mode. Use the ◀ arrow ▶ buttons to select ON or OFF. (Default OFF) Press the * button to save the selection to memory. Two short beeps will let you know you have successfully set the function and the meter will revert to the last displayed function.

Scan Mode - SCAN



The Scan mode will automatically scroll the display between Volts, Amps, Hertz (Frequency), and Watts (Power) displaying each for about 3 seconds. If the ◀ arrow ▶ buttons are pressed the Scan mode is temporarily suspended and the buttons may be used to manually scroll through the measured parameters. If no button is pressed for 10 minutes the Scan mode is resumed.

To access the Scan mode, hold the * button for two seconds. Use the ◀ arrow ▶ buttons to scroll until SCAN is in the display. Press * to select the Scan mode. Use the ◀ arrow ▶ buttons to select ON or OFF. (Default OFF) Press the * button to save the selection to memory. Two short beeps will let you know you have successfully set the function and the meter will revert to the last displayed function.

Alarms: The 8247 Multimeter can be set to generate alarms based on high current, low voltage, and high voltage.

High Current Alarm - HI

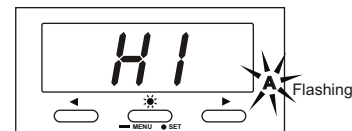

Set the meter to display current (Amperes) using the ◀ arrow ▶ buttons. The A function LED will be on. Hold the * button for two seconds to access the MENU. Use the ◀ arrow ▶ buttons to scroll until HI is in the display. Press * to select the High Current Alarm.



Use the ◀ arrow ▶ buttons to select ON or OFF (Default OFF). Press the * button to save the selection to memory and continue.



The present setting will appear in the display (Default 14.0). If the set point is acceptable, press the * button or wait for 15 seconds and the meter will revert to normal operation. Otherwise use the ◀ arrow ▶ buttons to select the desired value. For example, press and hold the right ▶ button to scroll up to 28.0 Amperes.



Press the * button when the desired set point is displayed and the new value will be saved to memory. Two short beeps will let you know you have successfully set the new value and the meter will revert to normal operation.*

* The minimum high current alarm setting is 10A. Even if the setting is made less than 10A, the alarm will still respond at 10A.

Low Voltage Alarm - LO



Set the meter to display voltage using the ◀ arrow ▶ buttons. The V function LED will be on. Hold the * button for two seconds to access the MENU. Use the ◀ arrow ▶ buttons to scroll until LO is in the display. Press * to select the Low Voltage Alarm.



Use the ◀ arrow ▶ buttons to select ON or OFF (Default OFF). Press the * button to save the selection to memory and continue.



The present setting will appear in the display (Default 105.0). If the set point is acceptable, press the * button or wait for 15 seconds and the meter will revert to normal operation. Otherwise use the ◀ arrow ▶ buttons to select the desired value. For example, press and hold the right ▶ button to scroll up to 110 Volts.



Press the * button when the desired set point is displayed and the new value will be saved to memory. Two short beeps will let you know you have successfully set the new value and the meter will revert to normal operation.

High Voltage Alarm - HI

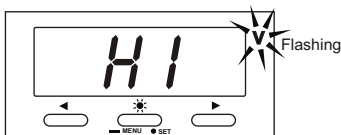

Set the meter to display voltage using the ◀ arrow ▶ buttons. The V function LED will be on. Hold the * button for two seconds to access the MENU. Use the ◀ arrow ▶ buttons to scroll until HI is in the display. Press * to select the High Voltage Alarm.

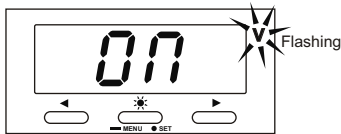

Use the ◀ arrow ▶ buttons to select 0n or OFF (Default OFF). Press the * button to save the selection to memory and continue.

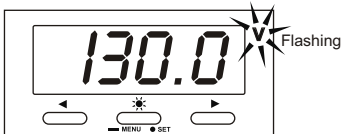

The present setting will appear in the display (Default 130.0). If the set point is acceptable, press the * button or wait for 15 seconds and the meter will revert to normal operation. Otherwise use the ◀ arrow ▶ buttons to select the desired value. For example, press and hold the right ▶ button to scroll up to 250 Volts.



Press the * button when the desired set point is displayed and the new value will be saved to memory. Two short beeps will let you know you have successfully set the new value and the meter will revert to normal operation.

Acknowledging an Alarm

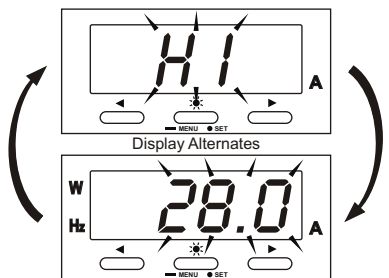

The alarm system is capable of recognizing more than one alarm condition at a time. If more than one alarm is set, the meter will continuously check for each alarm condition. If an alarm condition occurs while in scan mode, or while displaying a different parameter, the display will shift to the alarm value.

If an alarm occurs, the audible alarm will sound and the display will alternate between the type of alarm and the measured value.

Silence by pressing the * button. Display will alternate between the alarm condition and the value. Every 5 minutes the alarm will give four beeps and display the alarmed parameter. This will continue until the alarm condition is cleared, or the alarm function is turned off, or the set point changed.

If in Sleep Mode an alarm will "wake up" the meter and it will function as above. After 10 minutes of no acknowledgment it will re-enter the Sleep mode. Every 5 minutes it will give four audible beeps and display the alarmed condition and measured value for 30 seconds before going back to sleep.

If a second alarm condition occurs while the first alarm condition is still active, it will also have to be acknowledged to stop the alarm sound. The meter will continue to display the most recent alarm condition. If that alarm condition is cleared by values returning to normal, the meter will not indicate the status of prior acknowledged alarms. Once you have acknowledged alarms, check all parameters periodically or reset scan mode to be sure you are aware of all conditions.

Displaying the Code Revision

For customer service convenience, all models are able to display the revision of software installed in the meter. To see the software revision for meters with a single button, press and hold the center (*) button. To see the revision on meters with three buttons, press and hold the two ◀ arrow ▶ buttons. In either case, the power-up test will be performed and the software revision will be displayed.

Mounting Methods

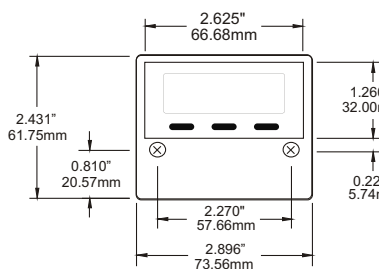

1 THROUGH HOLE MOUNT

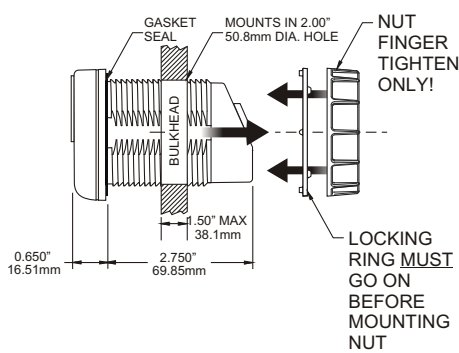

2 PANEL MOUNT

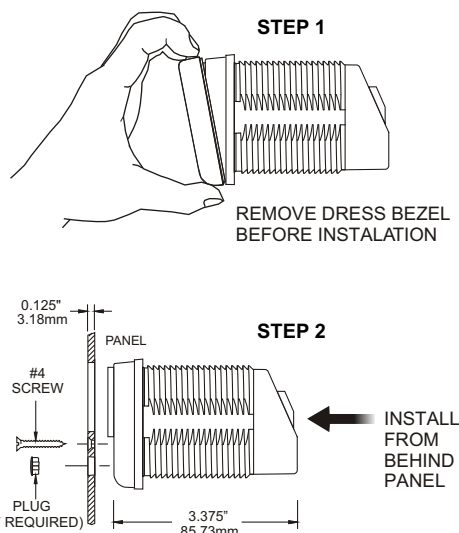

Mounting Methods

Any Blue Sea Systems product with which a customer is not satisfied may be returned for a full refund or replacement at the option of Blue Sea Systems for a period of two years from the date of purchase. Blue Sea Systems warrants that this product (1) will be free of defects in workmanship or material, and (2) will give the purchaser the service and satisfaction the purchaser has a right to expect. The benefits and limitations of this warranty shall extend only to the original purchaser.

To obtain warranty service, mail or deliver the Blue Sea Systems product or part to the following address:

Blue Sea Systems Inc.
425 Sequoia Drive Bellingham, WA 98226 USA

Please include a written explanation of the problem or defect. Before warranty performance will be rendered by Blue Sea Systems, you must submit a purchase receipt or other proof of purchase, reflecting the date of purchase to be within two years of the date the product is mailed or shipped to Blue Sea Systems for warranty service.

This warranty covers normal commercial or consumer use. It does not cover damage that occurs in shipment or that results from alteration, accident, misuse, abuse, neglect or failure to follow printed instructions.

TO THE EXTENT PERMITTED BY LAW, THIS WARRANTY IS EXCLUSIVE, AND IS MADE EXPRESSLY IN LIEU OF ALL OTHER WARRANTIES, INCLUDING THE WARRANTIES OF MERCHANTABILITY AND FITNESS FOR PARTICULAR USE AND OF ALL OTHER OBLIGATIONS OR LIABILITIES ON THE PART OF BLUE SEA SYSTEMS.

Blue Sea Systems does not assume, or authorize any other person to assume for it, any other liability in connection with the sale of this product. This warranty shall not be extended, altered or varied except by a written instrument signed by Blue Sea Systems and the purchaser. Blue Sea Systems makes no warranty whatsoever in respect to accessories or parts not supplied by it. No attempt by Blue Sea Systems or its representatives to remedy any defects shall constitute a waiver of any of the limitations of this warranty.

To the extent permitted by law, the remedies of repair or replacement set forth in this warranty are exclusive, and Blue Sea Systems shall not be liable for any loss or incidental or consequential damages resulting, directly or indirectly, from the use or loss of use of its products. The liability of Blue Sea Systems shall not, except as expressly provided herein or as required by law, exceed the price of the product or part on which such liability is based. This limitation of remedy shall preclude, to the extent permitted by law, recovery under this warranty of any expenses or loss by the purchaser for downtime or for making up downtime, recovery of damages for which the purchaser may be liable to other persons, recovery for damage to other property, and recovery for injury to or death of any person.

Some states do not allow limitations on how long an implied warranty lasts, or the exclusion or limitation of incidental or consequential damages, so some or all of the above limitations or exclusions may not apply to you. This warranty gives you specific legal rights, and you may also have other rights which vary from state to state.

Wiring Diagram

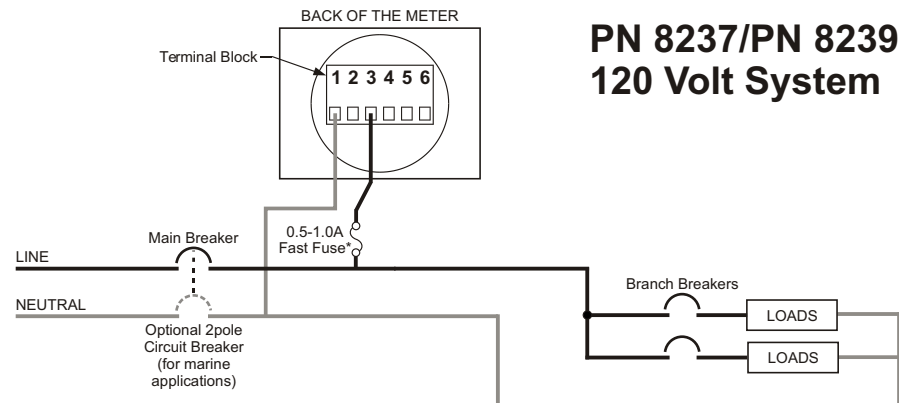

PN 8237/PN 8239 120 Volt System

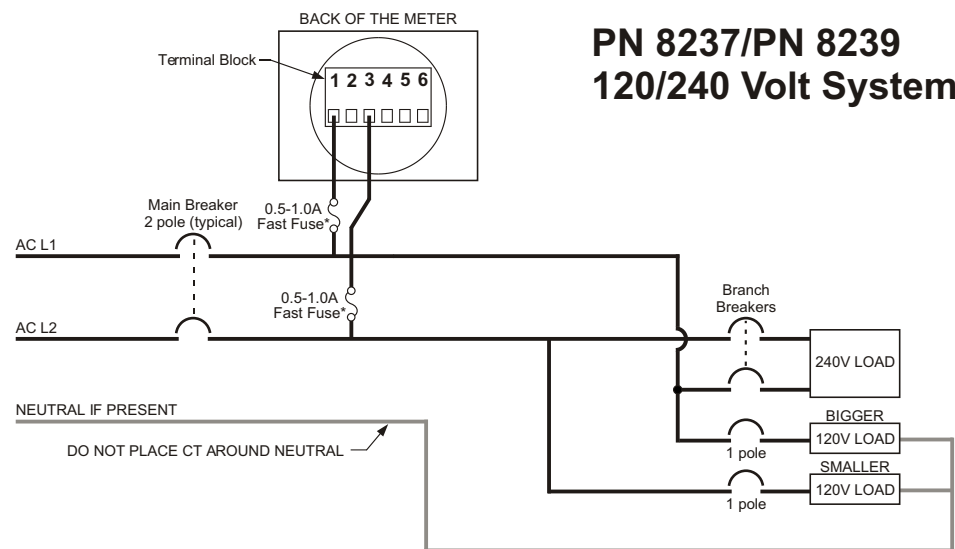

PN 8237/PN 8239 120/240 Volt System

* Use Blue Sea Systems' PN 5020 Fuseholder / PN 5202 Fuse AGC 0.5 Amp

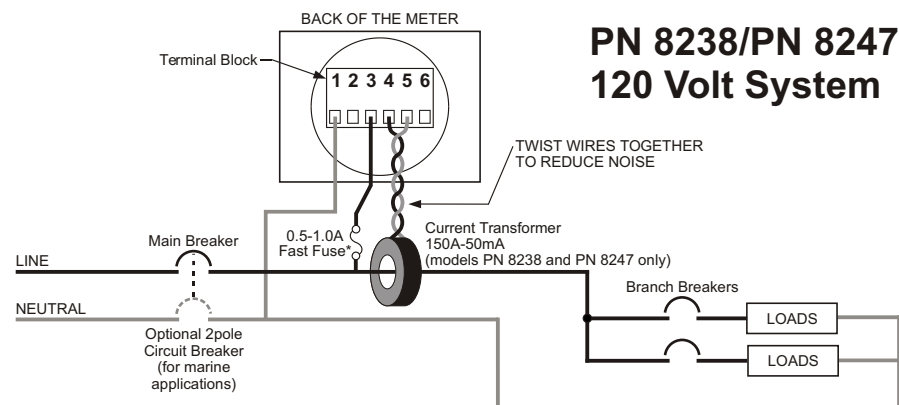

PN 8238/PN 8247 120 Volt System

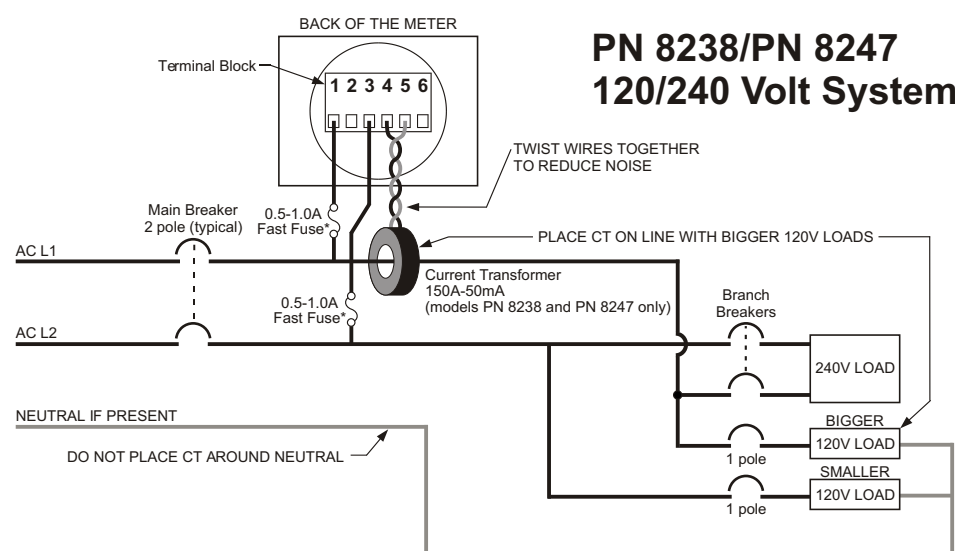

PN 8238/PN 8247 120/240 Volt System

* Use Blue Sea Systems' PN 5020 Fuseholder / PN 5202 Fuse AGC 0.5 Amp

Wire by Wire Instructions

NOTE:

All meter wiring #16 AWG
All models requires wire #1 and #3.
Wire #4 and #5 are required for PN 8238 and PN 8247 only.

Wire #1 (Neutral or L1 for 240V)---Connects terminal #1 of the meter to the AC Neutral for 120 Volt AC systems. For 240 Volt AC systems this wire is connected to L1, supplying one leg of the 240V AC. When used in a 240 Volt AC system this conductor must be fused with a 0.5A fuse in a holder with appropriate rating.

Wire #2 NOT USED

Wire #3 (L1 or L2 for 240V)

---This wire and wire #1 supplies power to the meter and the voltage to be measured. This wire must be protected by a fast acting fuse rated at 0.5A. Both the fuse and fuse holder must carry the appropriate voltage rating.

The next two wires must be a twisted pair to avoid electrical system noise that will affect the accuracy of current measurement. These may be twisted by hand or by using an electric drill motor, or twisted pair wire may be purchased from most electrical supply companies.

NOTE:

The two wires from the CT do not have polarity indicated. The polarity does not make a difference for current measurement but for Power measurement it does. **IF THE POWER NUMBER IS ZERO REVERSE THE CT SENSE LEADS.**

Wire #4 (Current Transformer Sense)---Is one of the sense leads from the CT. It must be a twisted pair with Wire #5. This wire carries a continuous 50mA under full load and may have intermittent currents two or three times higher. It must be securely connected under terminal #4 on the back of the meter. The CT sense leads may be extended up to 25 feet but the connections must be well made as high resistance connections can affect the accuracy of the current measurement.

Wire #5 (Current Transformer Sense)---Wires #4 and #5 provide the mA signal (generated by current flow in the primary conductor passing through the CT) to the meter for current measurement. It must be securely connected to terminal #5 on the back of the meter. It must be a twisted pair with Wire #4. See also wire #4.

Wire #6 Not used.

Blue Sea Systems Inc.
425 Sequoia Drive Bellingham, WA 98226 USA
Phone (360)738-8230 Fax (360)734-4195
E-mail conduct@blueseas.com www.blueseas.com