

AC & DC Power Distribution Panel

PN 8684 / PN 8685 8 Position AC / 16 Position DC

Panel Specifications

Material:	0.125" 5052-H32 Aluminum Alloy	
Primary Finish:	Chemical Treatment per Mil Spec C-5541C	
Final Panel Finish:	Graphite color 2 part textured Polyurethane	
Amperage Rating:	Panel Main Bus 100 Amperes	
Voltage Rating:	8684 12 Volts DC* / 120 Volts AC 8685 12 Volts DC* / 230 Volts AC	
	* Panels can be upgraded to 24 volts with PN 8240, 18-32V DC voltmeter.	
	Inches	Millimeters
Overall Dimensions:	14-3/4 x 10	374.7mm x 254.0mm

Panel Features

AC 8684 & 8685

- AC main plus six AC branch circuit breaker positions

AC 8684

- Three 15 Ampere branch circuit breakers installed
- One double-pole 30 Ampere AC main circuit breaker
- 0-150 Volt AC voltmeter

AC 8685

- Three 8 Ampere branch circuit breakers installed
- One double-pole 16 Ampere AC main circuit breaker
- 0-250 Volt AC voltmeter

DC 8684 & 8685

- Sixteen DC circuit breaker positions, ten 15A circuit breakers installed
- 8-16 Volt voltmeter with 3 position switch for multiple battery banks
- 0-100 Ampere DC ammeter with remote shunt
- All positive, ground and grounding buses installed, fully pre-wired

- ✓ It is not possible within the scope of these instructions to fully acquaint the installer with all the knowledge of electrical systems that may be necessary to correctly install this product. If the installer is not knowledgeable in electrical systems we recommend that an electrical professional be retained to make the installation.
- ✓ If either the panel front or back is to be exposed to water it must be protected with a waterproof shield.
- ✓ The panels must not be installed in explosive environments such as gas engine rooms or battery compartments as the circuit breakers are not ignition proof.
- ✓ The main positive connection must be disconnected at the battery post to avoid the possibility of a short circuit during the installation of this distribution panel.
- ✓ The panel should be installed in a suitable cabinet such that the back side is not exposed to personnel once installation is complete. It is recommended that the cabinet closure be such that the back of the panel cannot be accessed by children or others trying to reach something other than the electrical system for service.
- ✓ An insulating guard should be installed over the AC circuitry to prevent access when the DC portion of the panel is exposed for service.

Questions and Comments

We invite your questions and comments. You may contact us at the address below or by email at conduct@blueseasystems.com. To find out more about our full line of marine electrical products visit our web site at www.blueseasystems.com.

Blue Sea Systems Inc.
425 Sequoia Drive
Bellingham, WA 98226 USA

Phone (360) 738-8230
Fax (360) 734-4195
E-mail conduct@blueseasystems.com
www.blueseasystems.com

Installation Set Up

1. Disconnect all AC and DC power

Disconnect all AC power originating on or off the vessel. This includes inverters, generators, shore power attachments and any other device capable of supplying AC power to the ship's circuits.

Disconnect the main positive DC cable from all batteries to eliminate the possibility of a short circuit and to disable the inverter while installing the distribution panel. If there is a risk of sparking, remove the negative cable first.

2. Select mounting location and cut opening

If this panel is to serve as your main shore power disconnect circuit breaker, select a location which is not more than 10 feet from the shore power inlet or the electrical attachment point of a permanently installed shore power cord as measured along the conductors of the feed wires. If it is more than 10 feet additional fuses or circuit breakers must be installed within 10 feet of the shore power inlet.

Select a mounting location which is protected from water on the panel front and back and is not in an area where flammable vapors from propane, gas or lead acid batteries accumulate. The circuit breakers used in marine electrical panels are not ignition protected and may ignite such vapors.

Using the panel template provided, make a cutout in the mounting surface where the distribution panel is to be mounted. Do not yet fasten the panel to the mounting surface.

DC Installation

1. Select positive feed wire and negative return

Determine the positive feed (red) and negative return (black or yellow) wire size by calculating the total amperage of the circuits that will be routed through the panel. Blue Sea Systems' electrical panels are rated at 100 amp total capacity. The positive feed wire must be sized for 3% voltage drop at the 100 amp panel rating or the maximum amperage that will be routed through the panel in any particular installation, which ever is less. It is recommended that the positive feed wire be sized for the full panel capacity, which, in most cases, will require at least 2 AWG wire, assuming a 10 foot wire run between the panel and the batteries in 12 volt systems. Refer to the Wire Sizing Chart for other situations. In the case of panels with two or more columns of breakers, jumpers from positive bus to positive bus and from negative bus to negative bus should be the same size as the positive feed and the negative return wires.

Remember that the length of the circuit is the total of the positive wire from the power source and the negative wire back to the DC Negative Bus. Be certain that there is a fuse or circuit breaker of the correct size protecting the positive feed wire.

2. Install shunt, positive feed wire and negative return

The panel is supplied with an external shunt ammeter that must be connected in the positive feed line to the panel. The shunt may be mounted at any point in the feed line, but mounting it close to the panel will keep the sense wires that run to the meter short, minimizing voltage loss and interference, creating the most accurate meter reading.

Connect the positive feed wire from the positive source to either of the 2 large bolt terminals on the shunt top. This is now the shunt positive terminal. Connect an additional length of feed wire from the remaining shunt terminal, now the negative terminal, to the panel positive bus. Next, connect a minimum 16 AWG red wire from the screw on the side of the shunt positive terminal to the meter positive terminal and connect a second wire from the shunt negative terminal to the meter negative

DC Installation (continued)

terminal. There should be a 1 ampere fuse in the both sense wires near the shunt terminal. Be certain that on all 4 shunt connections the wire ring terminals sit directly on the brass blocks of the shunt without any washers in between.

Connect a negative return wire from the negative bus on the panel to DC negative.

3. Install battery bank voltage monitor wires

The panel is supplied with a meter and switch to monitor the voltage of three separate sources, usually the batteries. Connect a minimum 16 AWG red wire from each source to be monitored to each of the corresponding input wires of the switch. There should be a 1 ampere fuse in each positive wire near each source.

4. Install branch circuit wires

Determine the proper wire size for each branch circuit using the guidelines in step 4. Verify that the standard 15 amp circuit breakers installed in the panel are large enough for each branch circuit. Remove and replace with a higher amperage any that are undersized. Connect the positive (red) branch circuit wires to the load terminals of each circuit breaker. Connect each negative (black) branch circuit wire to the DC Negative Bus. **DO NOT CONFUSE THE DC NEGATIVE BUS WITH THE DC GROUNDING BUS.**

5. Optional - install grounding system wire

The grounding wire (bare, green or green with yellow stripe and normally non-current carrying) should not be confused with the negative wire (black or yellow and normally current carrying).

In *Boatowner's Illustrated Handbook of Wiring*, Charlie Wing identifies three purposes of DC Grounding:

1. Holding conductive housings of low voltage (under 50 volts) DC devices at ground potential by providing a low resistance return path for currents accidentally contacting the device cases.
2. Providing a low resistance return path for electrical current, preventing stray currents that may cause corrosion.

3. Grounding metal electrical cases to prevent emission from inside or absorption from outside of radio frequency noise (RFI).

ABYC requires that grounding wires be sized no smaller than one wire size under that required for current carrying conductors supplying the device to which the grounding wire is connected.

6. Installation of Backlight System

Connect the yellow negative wire to the panel DC negative bus. **Do not confuse with the AC neutral bus or grounding busses.**

To activate the label lights by the boat's battery switch, connect the red positive wire to the DC positive bus with a fuse. **Do not confuse with the AC hot bus.**

To activate the label lights by an independent switch or breaker, connect the red positive wire to the load side of a DC switch or breaker.

7. Optional Branch LED's

This panel is supplied with LED's pre-installed in all optional branch positions. For future expansion of the panel remove the positive leg of the LED from the negative bus and connect it to the load side of the corresponding branch circuit breaker.

Note

All Blue Sea Systems' DC electrical distribution panels are furnished with 15 amp AC/DC circuit breakers. This rating was selected to minimize the need for removing the panel's circuit breakers and reinstalling different size circuit breakers. As shown in the Wire Sizing Chart included with these instructions, even 16 AWG wire, which is the minimum wire size recommended by ABYC, has an allowable amperage greater than 20 amps. Additionally, it would be rare to have more than 15 amps of current flowing in any one circuit. Therefore, 15 amp circuit breakers will satisfy the vast majority of marine circuit protection situations.

AC Installation

1. Install branch circuit wires

Determine the proper wire size for each branch circuit using the chart below. Verify that the standard circuit breakers installed in the panel are correct for each branch circuit. Remove and replace any that are incorrectly sized. The circuit breaker must have a rating less than the allowable amperage of the wire, yet greater than the circuit's continuous current.

Connect each branch circuit hot (black) to the appropriate load terminal. Connect each branch circuit neutral (white) to one of the screws on the neutral bus. Connect each branch safety ground wire (green) to one of the screws of the safety ground bus.

Do not confuse the neutral current carrying wires (sometimes called ground) with the green normally non-current carrying wires (sometimes called grounding). These two wires must be connected only at the source of power, nowhere else.

AC Wire sizing chart

Use the wire sizing chart below to determine the minimum branch and feed circuit wire sizes.

Allowable Amperage of Conductors

Wire Size (AWG)	Outside Engine Spaces	Inside Engine Spaces
16	25.0	21.3
14	35.0	29.8
12	45.0	38.3
10	60.0	51.0
8	80.0	68.0
6	120.0	102.0
4	160.0	136.0
2	210.0	178.5

Note: This chart assumes wire with 105°C insulation rating and no more than 2 conductors are bunched. Not suitable for sizing flexible shore power cords.

This wire size chart will allow conductors to reach their full 105°C rated temperature. Most installations benefit from using wires one or two sizes larger than shown in this chart.

2. Install feed circuit wires

Install the feed wires from the shore power inlet or other AC source, referring to the wire sizing chart to select the correct wire size. Connect the black AC hot, white AC neutral and green AC safety ground as shown in the illustration.

If the feed wires are from the shore power inlet or the electrical attachment point of a permanently installed shore power cord and the inlet or attachment point is more than 10 feet from this panel, an additional fuses or circuit breakers must be installed within 10 feet of the shore power inlet. The measurement is made along the conductors.

3. Optional Branch LED's

This Panel is supplied with LED's pre-installed in all optional branch positions. For future expansion of the panel remove the hot leg of the LED from the AC Neutral Bus and connect it to the Load side of the branch circuit breaker.

Note

All Blue Sea Systems' AC electrical distribution panels are furnished with 15 amp or 8 amp circuit breakers for branch circuits. 15 amp circuit breakers are used in all 120 volt panels and 8 amp circuit breakers are used in all 230 volt panels. These ratings were selected to minimize the need for removing the panel's circuit breakers and reinstalling different size circuit breakers. It is very rare to have more than this amount of current flowing in any one circuit. Therefore, these circuit breakers will satisfy the vast majority of marine circuit protection situations.

Panel Mounting and Testing

1. Apply branch circuit labels and mount panel

Apply a label for each of the branch circuits from the 60 basic labels provided. If the appropriate label is not included, AC and DC extended Label Sets of 120 labels each may be ordered from your marine supplier (PNs 8039 and 8067). Individual labels are also available from Blue Sea Systems for specific applications. Refer to the label order form for a complete listing of individual labels.

Fasten the panel to the mounting surface using the panel mounting screws supplied with the panel.

2. Testing

- ☑ Reconnect the battery cables to the battery terminals and turn the main switch on to supply power to the panel. Turn on all branch circuits and test the voltage at the panel. Compare this voltage to the battery terminal voltage to determine that the voltage drop is within 3%. With all branch circuits still on, test the voltage at one device on each circuit to determine that there is a 3% or 10% drop as is appropriate.
- ☑ Connect the shore power cable to the boat AC power inlet. Do not connect the shore power cable to the shore power pedestal. Instead run the shore power cable such that the shore power plug is next to the AC panel. With an Ohmmeter verify that the pins of the shore power plug are connected to the appropriate terminals of the panel. Refer to ABYC E-11 Figure 13 or 14 or NEC / NEMA documents for the standard pin arrangements for your plug.
- ☑ Connect the vessel's shore power and verify the Reverse Polarity light is not illuminated. If the red Reverse Polarity light is on then either the hot and ground or the hot and neutral wires have been crossed. Starting at the panel, trace the connections back as far as necessary to locate the error.

- ☑ Using a multimeter where the power source is connected to the panel verify:

PN 8085 - 120 Volt AC

- a. 120 volts between hot and neutral (nominal, this may vary depending on source voltage)
- b. 120 volts between hot and ground.
- c. 0 volts between neutral and ground

PN 8185 - 230 Volt AC

- a. 230 volts between hot and neutral (nominal, this may vary depending on source voltage)
- b. 230 volts between hot and ground.
- c. 0 volts between neutral and ground.

- ☑ Turn on each branch circuit to verify power to each circuit.

Reference

Applicable Standards

- American Boat and Yacht Council (ABYC) Standards and Recommended Practices for Small Craft sections: E-1, E-3, E-9.
- United States Coast Guard 33 CFR Sub Part 1, Electrical Systems

The Purpose of a Panel

There are six purposes of a marine electrical panel:

- Power distribution
- Circuit (wire) protection
- Circuit ON/OFF switching
- Reverse Polarity Indication
- Metering of voltage and amperage (In panels with meters)
- Condition Indication (circuit energized)

Useful Reference Books

- Calder, Nigel, 1996: *Boatowner's Mechanical and Electrical Manual*, 2nd edition, Blue Ridge Summit, PA: TAB Books, Inc.
- Wing, Charlie, 1993: *Boatowner's Illustrated Handbook of Wiring*, Blue Ridge Summit, PA: TAB Books, Inc.

Guarantee

Any Blue Sea Systems product with which a customer is not satisfied may be returned for a refund or replacement at any time. Reference Blue Sea Systems' Digital Meter installation manual for specific meter warranty information.

Related Products from Blue Sea Systems

- High Amperage Fuses and Circuit Breakers for positive feed wires
- High Amperage Battery Switches
- Terminal Blocks and Common Bus Connectors
- AC and DC Voltmeters and Ammeters

Wire Sizing Chart

1. Calculate the maximum sustained amperage of the circuit. Measure the length of the circuit from the power source to the load and back.
2. Does the circuit runs in an **engine space** or **non engine space**.
3. Calculate **Famps** (Feet x amps). Multiply circuit length by max. current.
4. Base the wire on either the 3% or 10% **voltage drop**. In general, items which affect the safe operation of the boat and its passengers (running lights, bilge blowers, electronics, panel feed lines) use 3%; all other loads use 10%.
5. Starting in the column which has the right **voltage** and **voltage drop**, run down the list until arriving at a value which is greater than the calculated **Famps**. Move left to the **Ampacity** column to verify that the total amperage of the circuit does not exceed the maximum allowable amperage of the wire size for that row. If it does, move down until the wire ampacity exceeds the circuit amperage. Finally, move left to the **wire size** column to select the wire size.

Example

- a. A 12 volt system at 10% drop with a 40' circuit x 45 amps = 1800 Famps. A wire size of 8 is required.

Wire Size	Wire Ampacity		Voltage →	Volt Drop →					
	non-engine	engine		3%	10%	3%	10%	3%	10%
16	25.0	21.3		86	288	173	576	230	768
14	35.0	29.8		138	459	275	918	367	1223
12	45.0	38.3		219	729	437	1458	583	1944
10	60.0	51.0		348	1159	695	2317	927	3090
8	80.0	68.0		553	1843	1106	3686	1474	4915
6	120.0	102.0		879	2929	1757	5858	2343	7811
4	160.0	136.0		1398	4659	2796	9319	3727	12425
2	210.0	178.5		2222	7408	4445	14815	5926	19754
1	245.0	208.3		2803	9342	5605	18684	7474	24912
0	285.0	242.3		3536	11788	7073	23576	9430	31434
00	330.0	280.5		4457	14858	8915	29715	11886	39620
000	385.0	327.3		5619	18731	11239	37462	14985	49950
0000	445.0	378.3		7086	23620	14172	47241	18896	62988

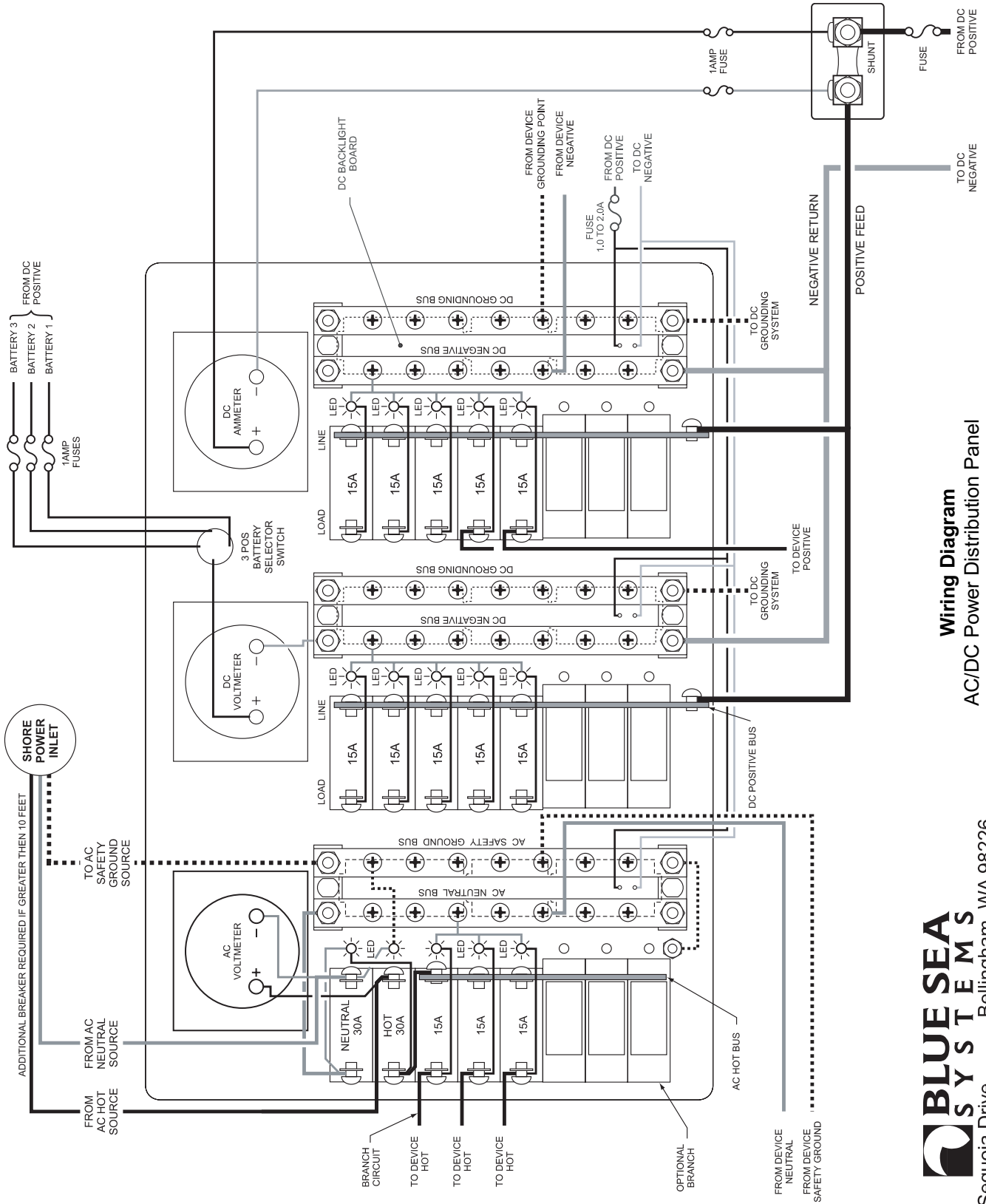

Wiring Diagram
 AC/DC Power Distribution Panel
 PN 8684

BLUE SEA SYSTEMS
 425 Sequoia Drive
 Bellingham, WA 98226
 Phone (360)738-8230 Fax (360)734-4195